

ECO LP-38 Transport Overpack

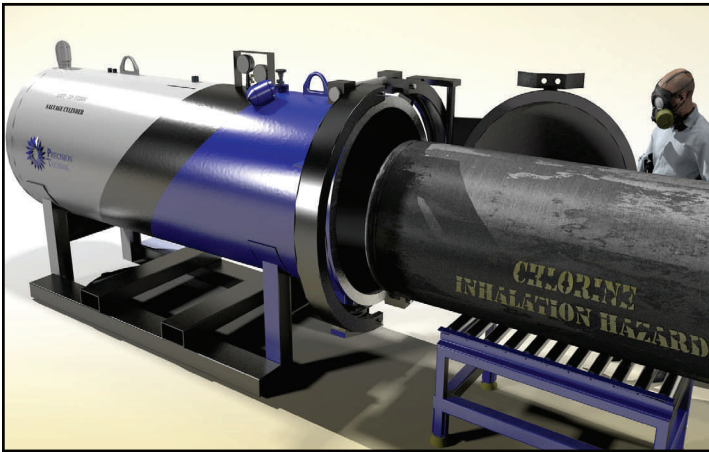

The ECO LP-38 is a DOT-exempt salvage cylinder for transport or storage of leaking, damaged, or deteriorated compressed gas cylinders. The unit was designed to address the transport needs of large diameter vessels, specifically 1-ton and Y-cylinders. Fabricated of carbon steel to ASME Section VIII Division 1 standards, the vessel has a working pressure of 450 psig. Gases and liquids released inside the salvage cylinder can be withdrawn via one of several universal fittings and then directed to an appropriate scrubber or repackaged. The ECO LP-38 vessel weighs approximately 5,500 pounds and is easily moved using a standard forklift. It can be used for routine, secure transport of cylinders containing hazardous gases or in emergency response situations that require rapid containment of a leaking or deteriorated cylinder. The closure hatch can be operated by one person, even when fully attired in chemical protective equipment. Additionally, the hatch is equipped with safety devices that prevent the vessel from opening when it is pressurized.

Features

Benefits

DOT-Exempt for all Class 2,3,6.1 Materials*	Permits Legal Transportation of Wide Range of Chemicals
Can Be Fitted with Rapid Open/Close Electric Driver	Seals and Secures Cylinder Inside Quickly and Easily
Working Pressure :450 psig	Safely Accepts Cylinders up to 36" Diameter
Weight: 5,500 pounds (vessel)	Allows Easy Lifting and Movement
Can Be Fitted with Heavy Duty Wheels (with brakes)	Easy Movement on Flat Surfaces
Cylinder Loading Table	Rapid, Simple, and Safe Cylinder Loading
Integrated Lifting Lugs	For Easy and Convenient Overhead Lifting
Pressurized Hatch Locks	Safe Operational Design
Liquid Drainage Port	Easy Removal of Liquefied Gas or Wash-Out Reagent
Gas Treatment Connection Port	Routes Internal Atmosphere to Sampling/Treatment System
Rugged Epoxy Coating	Resists Weathering and Wear From Use
Narrow Profile	Smaller Footprint for Storage and Movement
Integrated Forklift Channels	Minimizes Need For Special Transport Pallets
Auxiliary Penetration Port	Safe Penetration of Damaged Cylinder

*except acetylene

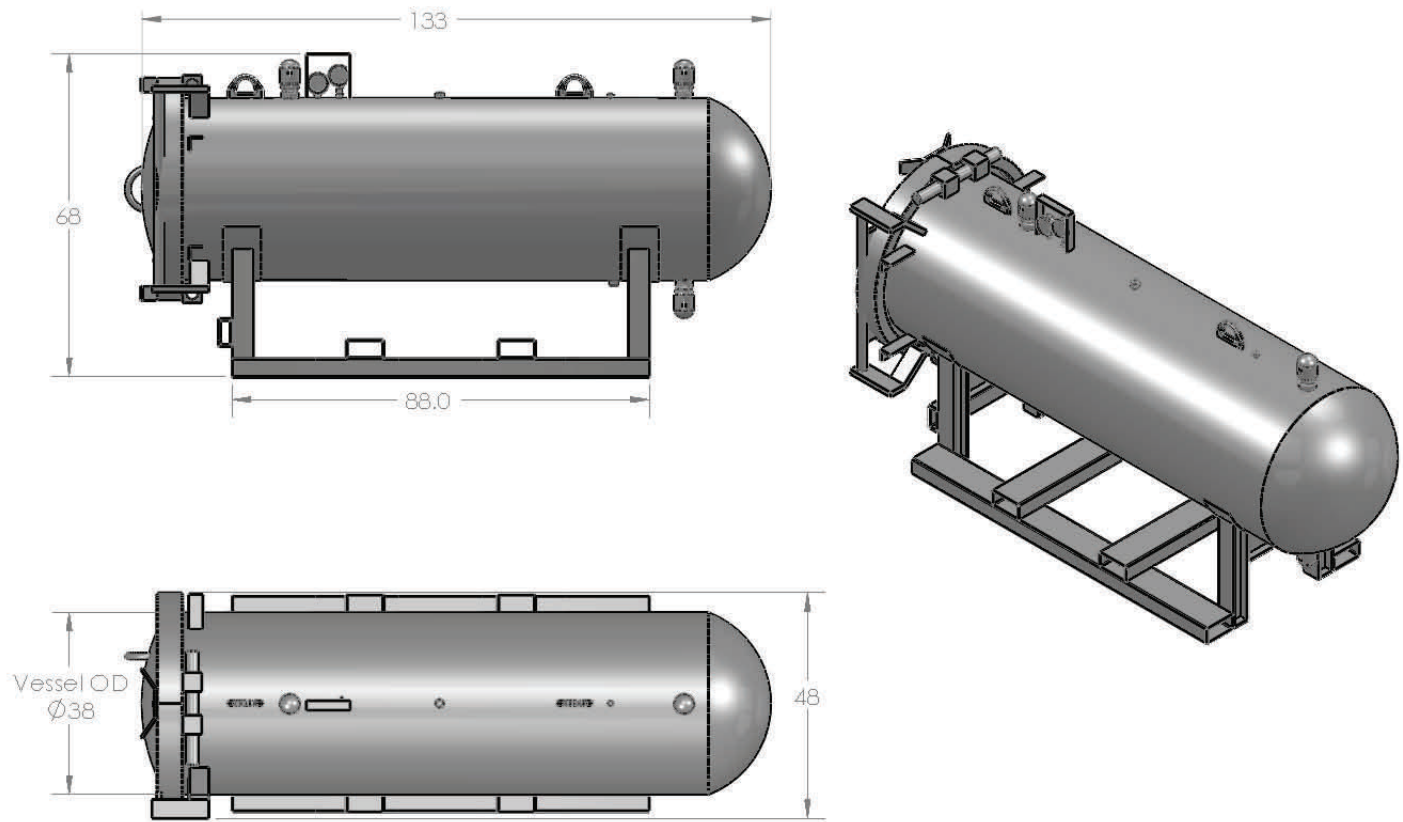

LP-38 Pressure Vessel Specifications

Overall Length 132" (3.4 m)

Working Pressure 450 psig (31 bar)

Internal Volume 71 ft³ (2 m³)

Diameter (ID) 37" (94 cm)

Hydrotest Pressure 585 psig" (40 bar)

Weight 5,500 lbs (2500 kg)



1445 Marietta Boulevard
Atlanta, GA 30318

PHONE 404 693 8388

FAX 404 352-3070

EMAIL info@precisiontechnik.com